



**MISSION
DRIVEN
PARTNERSHIPS**

Air Force Technology Transfer Program



Air Force Technology Transition & Transfer

Transition: Formal Acquisition process of delivering products to the Warfighter.

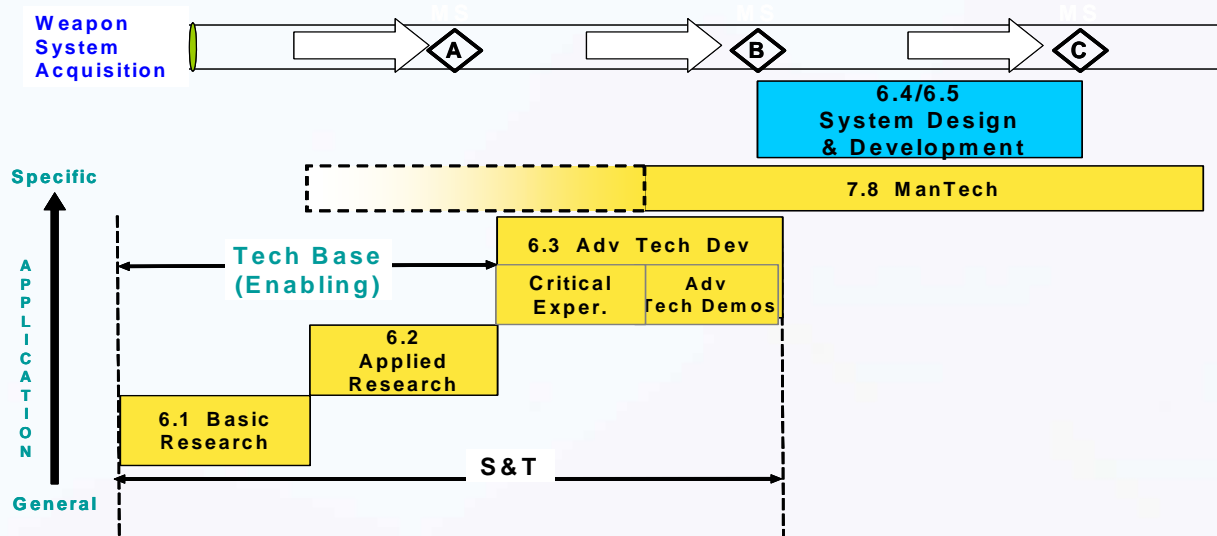

Transfer: Process of working with non-government entities to share and exchange technology (non-contract activities outside of the Federal Rules of Acquisition).



Technology Transfer Concept

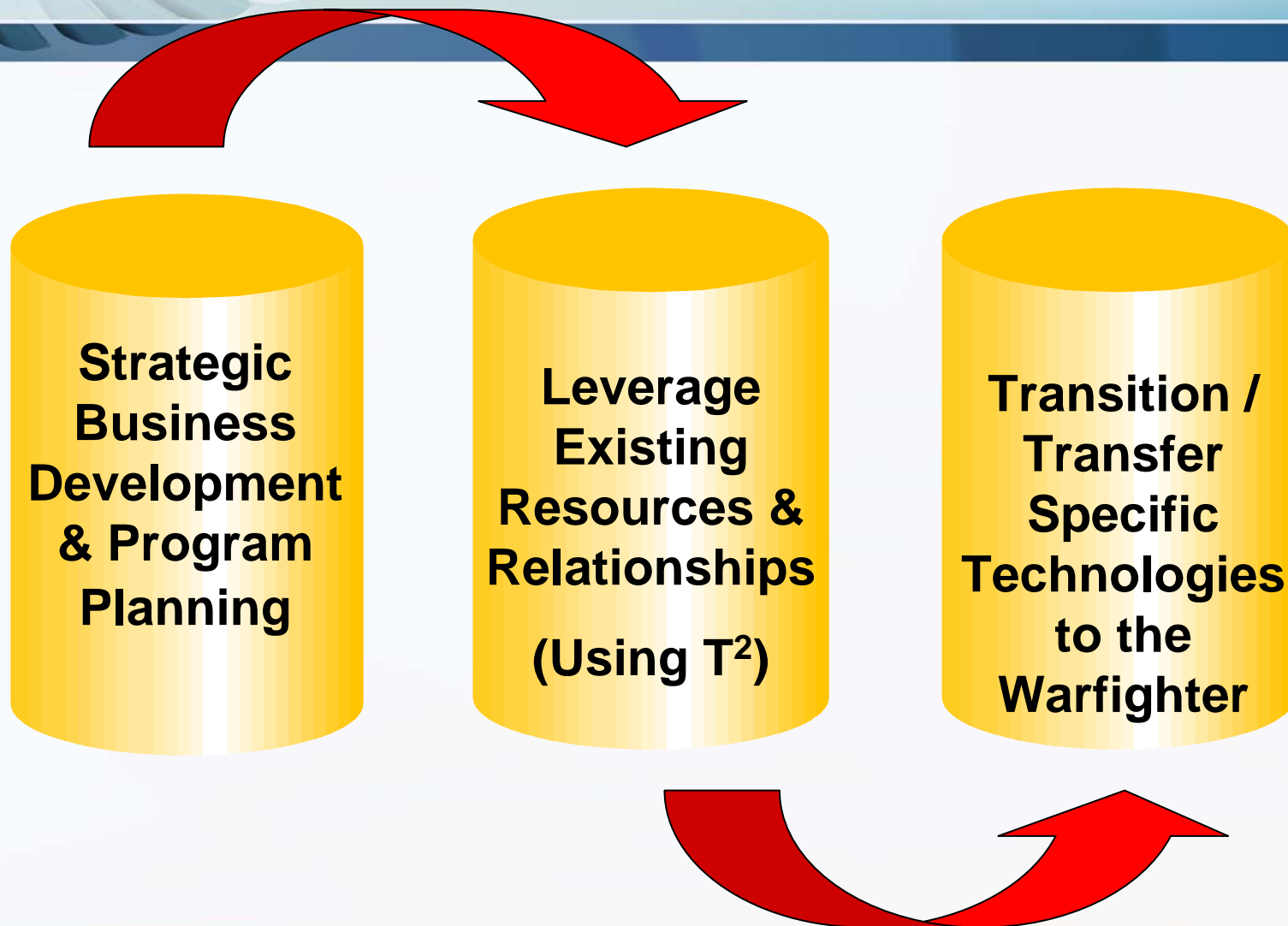



Technology Transfer Adds Value to Air Force Programs

- Brings Additional Dollars to Research Programs
- Expands Capabilities
 - Provide/Receive Facilities & Equipment
 - Maintain and Upgrade Current Facilities
 - Market Facilities to Commercial Partners
- Reduce the Overall Schedule of Programs
 - Collaborate on Research
 - Conduct Additional Research of Interest





Technology Transfer's Role in Acquisition

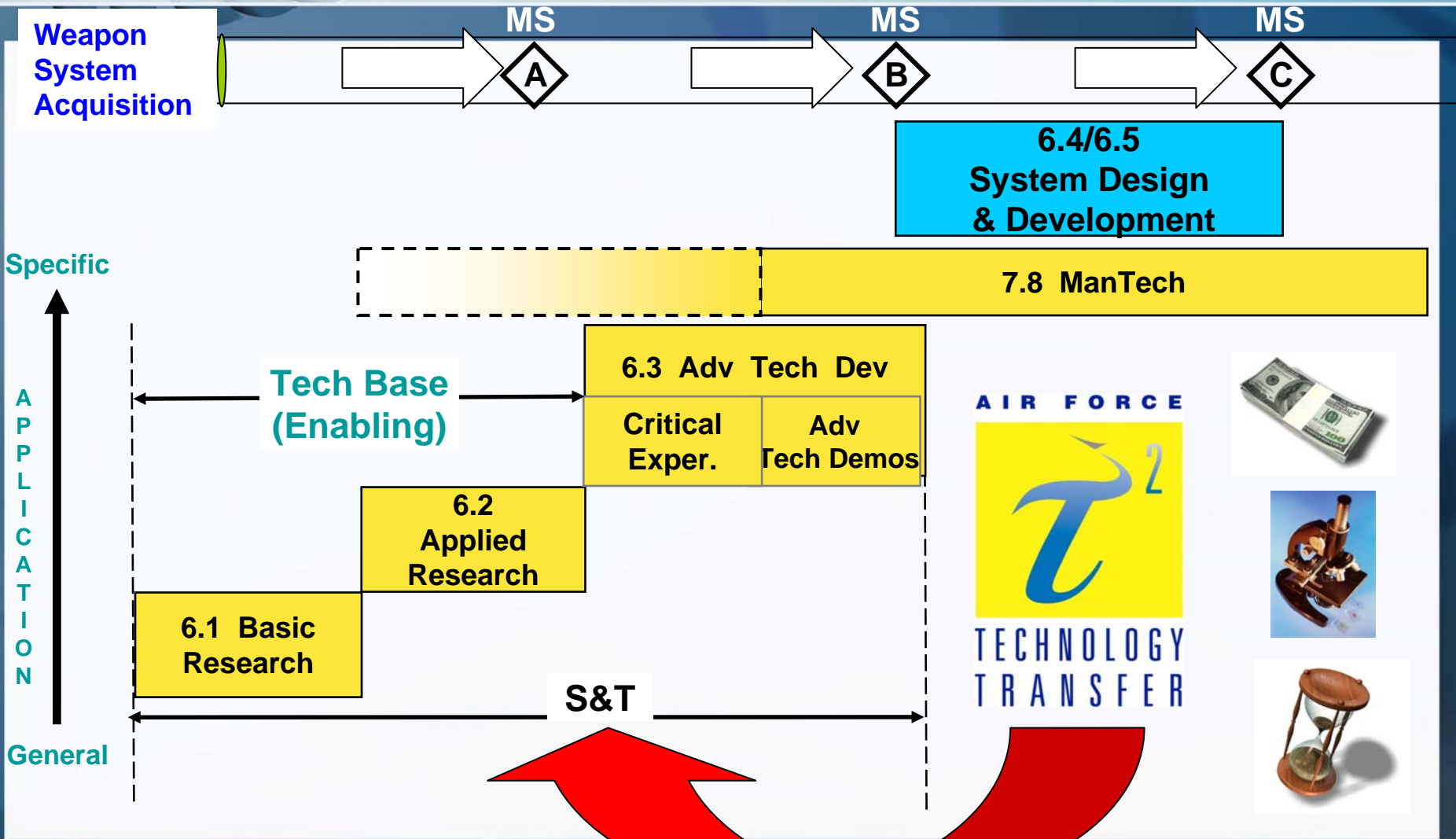



Conclusion

- T² facilitates Transition and is an Air Force acquisition strategy that supports the Warfighter
- T² provides a return on our AF S&T investment and enhances economic development

A I R F O R C E



**T E C H N O L O G Y
T R A N S F E R**